

Lane - Aire
Manufacturing Corporation

DETAIL AND SUBMITTAL SHEET

2820 El Presidio Street, P.O. Box 4485, Carson, CA 90749 • Tel: (323) 636-2324 • Fax: (310) 604-3395 • E-mail: laneaire@lane-aire.com
 7830 Cucamonga Ave., Suite 20, Sacramento, CA 95826 • Tel: (916) 732-2224 • Fax: (916) 732-2227 • E-mail: nocal@lane-aire.com

SP-1 Safety Post

The SP-1 Safety Post provides a convenient and safe method of climbing off and onto fixed access ladders. Available in steel with yellow powder coat and meets ANSI A 14.3 and OSHA requirements.

Safety Posts offer support for climbing on and off a fixed access ladder while maintaining a standing position.

Easy To Use

When reaching the top of the ladder, extending the Safety Post is easy to lift with just one hand, because of the built-in counter spring. Now you can step on or off the ladder in a safe standing position while gripping the post. A latch maintains the post at any height and is easily released for retracting the post. Safety features include an easy-to-grip square post and a ring for fall arrest attachment at the top.

Easy To Install

Safety Posts come pre-assembled and attaches directly to the top two rungs (square or round) with just two "U" bolts.



Model Number

SP-1 SAFETY POST



JOB:	MODEL NO.:
LOCATION:	SIZE:
ARCHITECT:	QUANTITY:
CONTRACTOR:	MATERIAL:
SUBCONTRACTOR:	DATE:

Drawing No. SP-1
 Please See Reverse Side For Details And Specifications

SAFETY POST

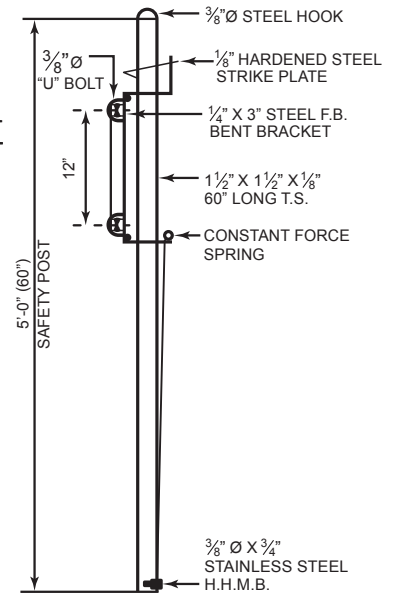
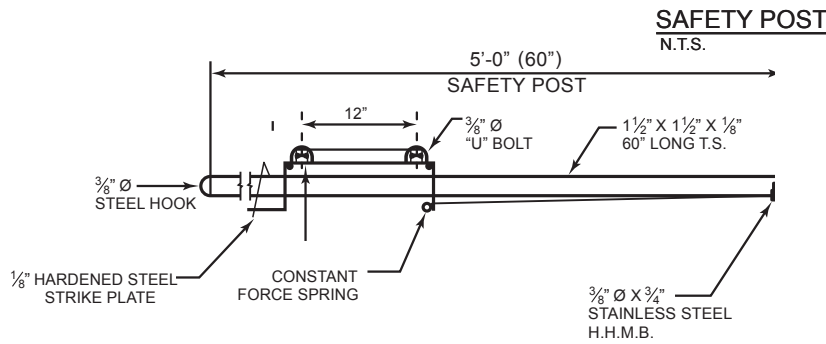
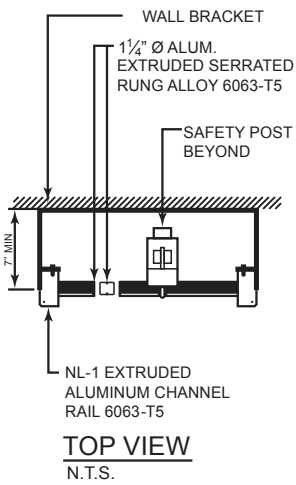
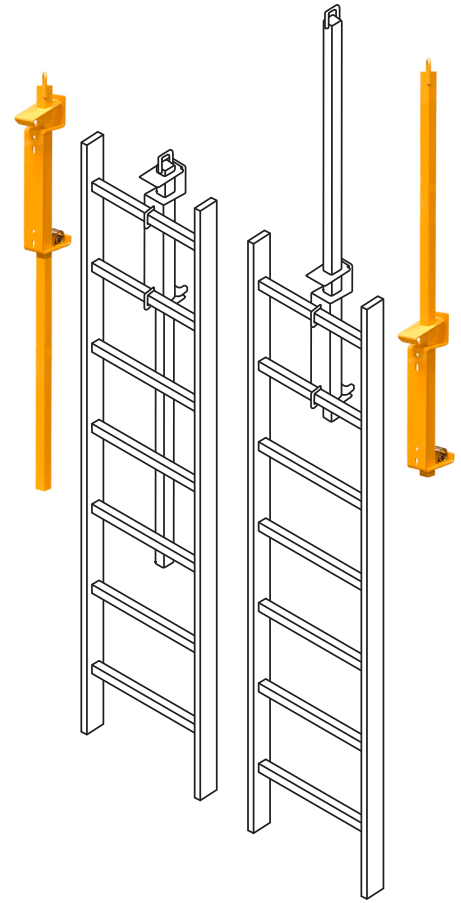
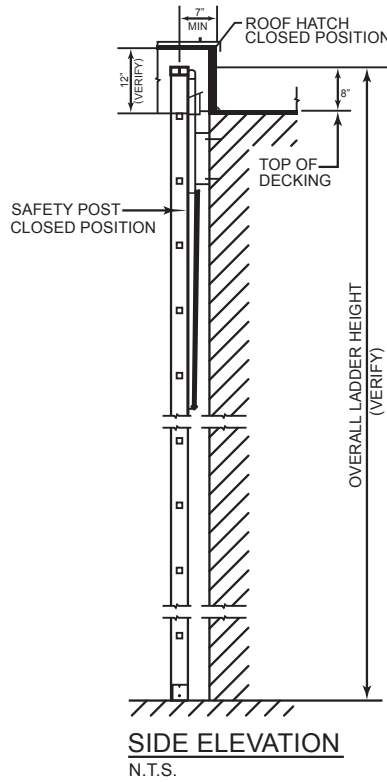
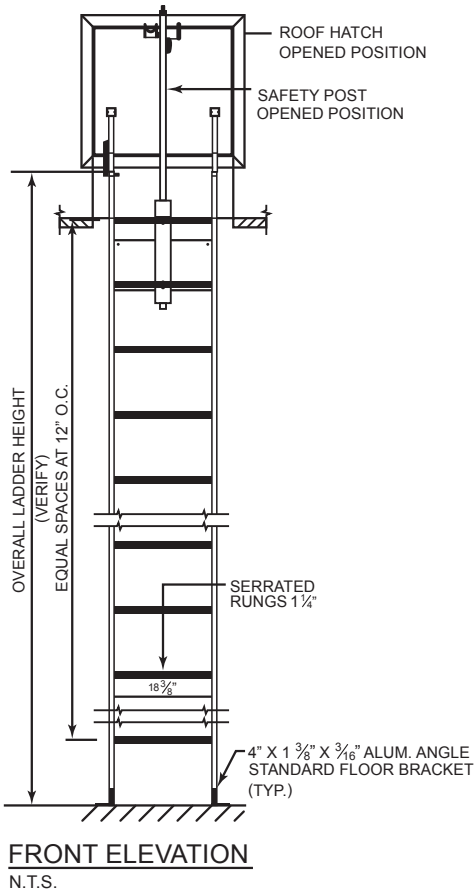

SPECIFICATIONS

PART 1 - GENERAL

1.1 Scope

A. Furnish Safety Post(s) as required.

1.2 Submittals

A. ___ copies of shop drawings shall be submitted to the architect for approval prior to fabrication.

1.3 Guarantee

A. A written guarantee will be provided certifying that the Safety Post shall be free of defects in material and workmanship for a period of 7 years from the date of purchase.

PART 2 - PRODUCTS

2.1 Manufacturer

A. Safety Posts shall be as distributed by Lane-Aire Manufacturing Corp., P.O. Box 4485, Carson, CA 90749, telephone number (323) 636-2324 or (714) 547-7744.

2.2 Materials

All steel components shall be finished with an exterior grade yellow powder coat.